

1. Introduction

Module **A-111 (VCO 2)** is a **voltage controlled oscillator**.

The VCO has a range of about 12 octaves, and produces four **waveforms** simultaneously: **pulse (rectangle), sawtooth, triangle and sine waves**.

The VCO's frequency is determined by the position of the range switch, tune and fine tune controls, and the voltage at the two pitch CV inputs, CV 1 and CV 2.

Footage (the octave of the fundamental) is set by the Range control, which has seven octave steps. The Tune control is used for **coarse tuning**, and the Fine control for **fine tuning** of the VCO pitch.

The A-111 can be modulated by both **exponential** and **linear FM (frequency modulation)**.

You can control the **pulse width** of the square wave either by hand, or by voltage control - **Pulse Width Modulation**, or **PWM** for short.

The A-111 has inputs for **Hard Sync** and **Soft Sync**.

2. VCO 2 - Overview

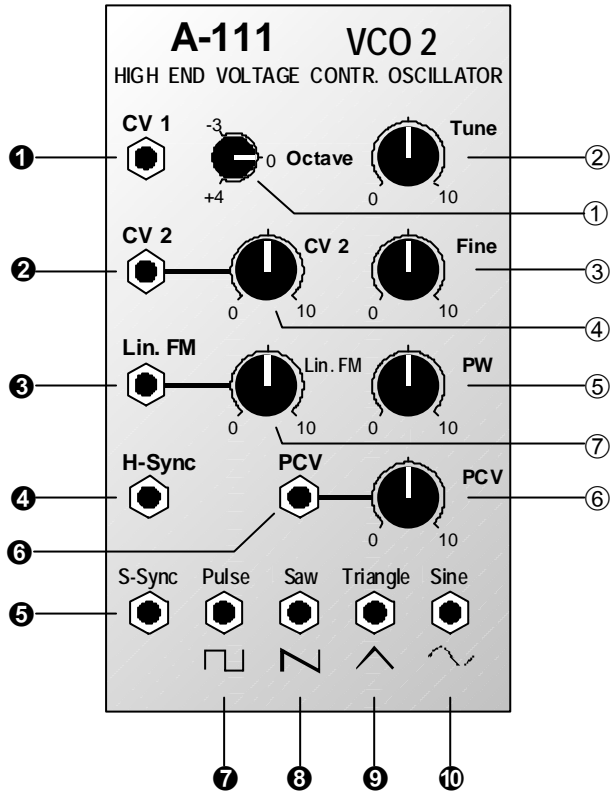

Controls:

- 1 **Range** : 7-position switch for octave selection
- 2 **Tune** : Control for coarse tuning
- 3 **Fine** : Control for fine tuning
- 4 **CV 2** : Attenuator for pitch CV at input "
- 5 **PW** : Manual control for pulse width
- 6 **PCV** : Attenuator for PWM voltage at PCV &
- 7 **Lin. FM** : Attenuator for voltage at linear FM input §

In- / Outputs:

- ! **CV 1** : Pitch control input (1 V/oct.)
- " **CV 2** : ditto, level adjustable with 4
- § **Lin. FM** : CV input for linear FM
- \$ **H-Sync** : Input for hard synchronisation
- % **S-Sync** : Input for soft synchronisation
- & **PCV** : Input for pulse width modulation CV
- /, (,), = : VCO outputs

3. Basics

3.1 Waveforms

Module A-111 puts out four waveforms simultaneously. All these signals have the same pitch, since all are controlled by the same CVs at inputs ! and " .

Sawtooth

The VCO's sawtooth waveform is available at output /. It has a 'cutting' sound, rich in overtones. All the harmonics of the fundamental are present, with a linear reduction in intensity as the harmonic series progresses - so that the second harmonic is half as strong, the third is one third, the fourth a quarter, etc. (see Fig. 1).

Sawtooth waves are ideal for synthesizing sounds which are rich in harmonics, such as percussion, brass or vocal timbres, and as the carrier input to a vocoder.

Pulse wave

The VCO produces a square / rectangle wave at output =. You can alter its **pulse width** (see Fig. 2) by hand or by voltage control (**pulse width modulation** or **PWM** for short).

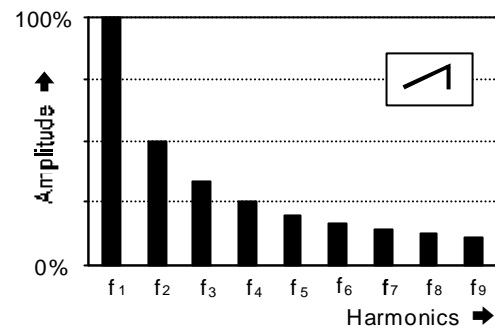

Fig. 1: Harmonic spectrum of a sawtooth

A **symmetrical pulse wave** (ie. an exact square wave, with a pulse width of 50%) has only odd harmonics of its fundamental (see Fig. 3) and produces a typically hollow sound.

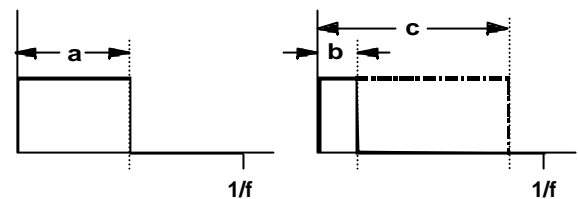

Fig. 2: Rectangle waves with different pulse widths

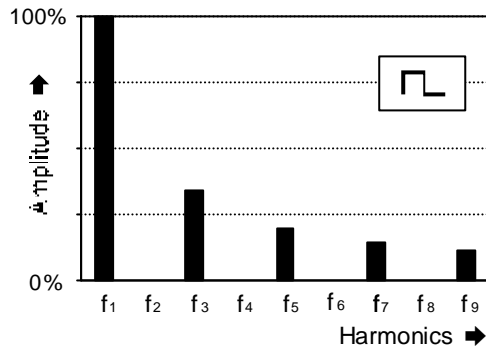

Fig. 3: Harmonic spectrum of a true square wave

The further the pulse width deviates from 50% (see Fig. 2, b and c), the weaker the lower harmonics become, and the more the sound gets thin and nasal.

Pulse waves are often used as a sound source in subtractive (filtered) synthesis, because of their rich overtones, and are good at producing woodwind-like timbres.

Triangle wave

A triangle wave (output) is poor in upper harmonics, and sounds softer and more mellow. It only contains odd harmonics, whose strength decreases exponentially - the third harmonic is a ninth as strong, the fifth 1/25, and so on.

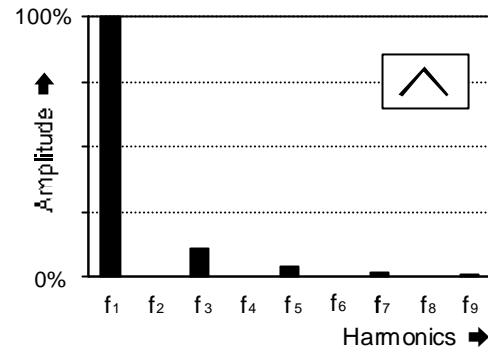

Fig. 4: Harmonic spectrum of a triangle wave

Because of their soft, rounded timbre, triangle waves are ideal for synthesizing timbres like flute, organ and vibes. Because of the comparative weakness of the upper harmonics, they are not ideal for treating with a low pass filter, in subtractive synthesis.

Sine wave

Sine waves are pure waves: they just contain the fundamental, without any harmonics (see Fig. 5). They are thus not suitable for subtractive synthesis (shaping sound with a filter) - as there's nothing to take away!

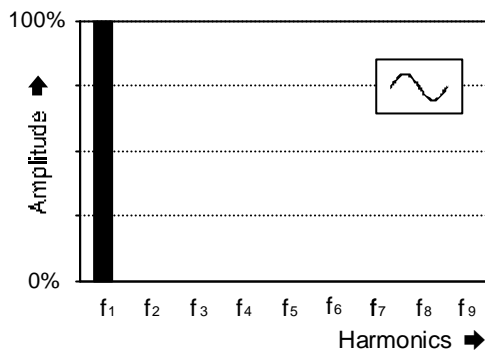

Fig. 5: Spectrum of a sine wave

3.2 Frequency Modulation (FM)

Since the frequency of the VCOs can be voltage controlled, that of course makes **frequency modulation** (FM) possible. The frequency changes conti-

nuously, depending on the incoming voltages at CV1 and CV2. In contrast with the standard VCO module (A-110), the A-111 provides two types of frequency modulation.

For **exponential FM** (like on the A-110) you simply input a modulation signal via the normal CV inputs, ! or ". For **linear FM** there is a dedicated CV input S, complete with attenuator.

If the modulation signal is in the **sub-audio range** (for instance modulation with a slow LFO), there'll be no real difference noticeable between the two types. The result in both cases is a typical vibrato (see Fig. 6).

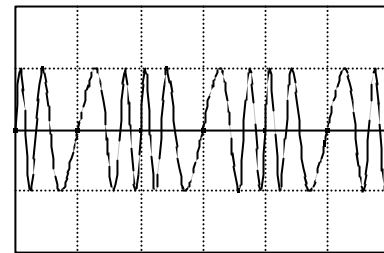

Fig. 6: Frequency modulation with a slow LFO (vibrato)

Completely different sounds will emerge, though, if the modulation frequency is in the **audio range**.

Exponential FM in the audio range

For exponential FM, patch the modulation voltages into **CV input !** or " (see Fig. 7).

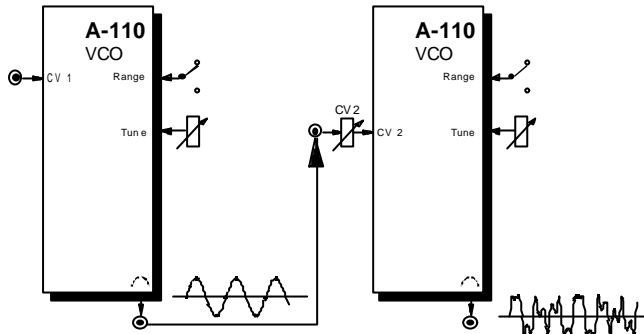

Fig. 7: Frequency modulation in the audio range

Thanks to the rapid changes in the modulated VCO's pitch, **side bands** are created: as well as the two original frequencies, you also get the frequencies created by their **sum and difference** (for instance a modulation frequency of 100 Hz and a carrier frequency of 500

Hz produce side bands at 400 Hz and 600 Hz).

When you try this out for the first time, start off with sine waves, and slowly raise the modulation frequency from the sub-audio into the audio range.

If you use waveforms other than sine waves in FM in the audio range, the sounds that result will be extremely complex and difficult to predict. A sawtooth, for instance, is like a vast number of sine waves of different frequencies - all of which will be represented in the modulated output, so that the final sound will be a complex mix of the buzzes, noises and tones produced by all the various sum and difference outputs.

With **exponential FM**, changes in control voltage produce **proportional changes in the pitch relationship** of the component sounds. This can have unwanted side-effects. If a 440 Hz VCO sine wave is modulated by a $2 V_{SS}$ amplitude sine wave (see Fig. 8), the top and bottom side-bands are respectively up and down one octave, at 880 Hz and 220 Hz. You might think that would be fine - but with modulation in the audio range, we hear the note half-way between these frequencies - 550Hz - and this is (not surprisingly) out of tune with the original 440 Hz carrier note.

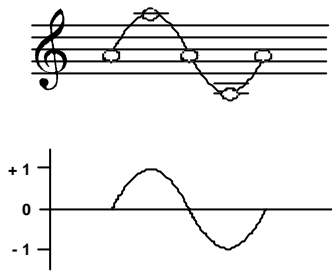

Fig. 8: Exponential FM in the audio range

Whenever you change pitch using exponential FM, the inevitable side effect of the change will be an unplanned and usually un-musical change in the relative pitch of the components of the sound.

If the side-effects of exponential FM aren't wanted, then you need to use the linear FM input on the A-111.

Linear FM in the audio range

Linear FM is now one of the standard building blocks of synthesis. Especially after the introduction and instant success of the Yamaha DX 7, in the early 80s, linear FM was hugely popular throughout the world, and is partly what people are referring to when they talk about

'digital' sounds. After being superceded in popularity by 'sample & synthesis' technology in the late 80s - and analog or analog-like instruments in the 90s - it is now appreciated again as a very useful source of timbres.

With linear FM, changes in control voltage produce **proportional changes in pitch, not in octaves**. It's a Hz/V rather than V/octave response.

This time, if you modulate a 440 Hz sine wave with a 220 Hz sine wave, the side-bands created will be at 220Hz and 660 Hz, and so the pitch at which we hear the modulated signal (halfway between 220 Hz and 660 Hz) will be 440 Hz - and thus **in perfect tune with the original carrier frequency**.

The relationship between the **carrier frequency f_c** and **modulator frequency f_m** is crucial to the timbre.

With **identical frequencies** for carrier and modulator, you end up with a timbre which is like a sawtooth put through a low pass filter (see Fig. 9 on page 8).

With a modulator frequency double the carrier frequency, you end up with something very like a pulse wave (see Fig. 10 on page 8).

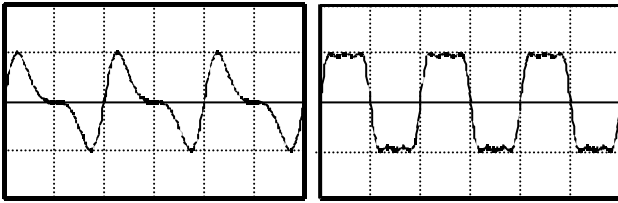
Fig. 9: $f_M = f_C$ Fig. 10: $f_M = 2 \times f_C$

If you choose non-related frequencies for the carrier and modulator, you can produce all sorts of vocal-like sounds, and radio interference imitations (see Fig. 11).

The results can be surprising, as just a tiny change in frequency can produce a drastic timbral alteration or effect (compare Fig. 10 with Fig. 12).

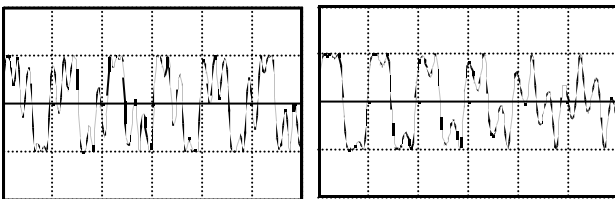
Fig. 11: $f_M = 3.3 \times f_C$ Fig. 12: $f_M = 2.05 \times f_C$

The other important influence on the end result is the intensity of the modulation - in other words, how high the Linear FM control 7 is set.

3.3 Synchronisation

What synchronisation means in this context is that the waveform of one VCO ('slave') is locked to the waveform of another ('master'), by connecting the audio out of the master VCO to the sync input of the slave.

In the A-111 two types of synchronisation are available: "**Hard Sync**" and "**Soft Sync**". There are accordingly **two Sync input sockets** (\$ and %).

Hard sync

Consider the following example (see Fig. 13 on page 9), in which the slave VCO is a triangle wave, and the master VCO is a rectangle wave. The waveform of the triangle wave changes direction every time the rectangle wave hits a rising or falling edge.

If the master VCO's frequency f_M is bigger than the slave VCO's f_S , then the slave's frequency is increased, to match the master exactly (see Fig. 13a: the 'synced' triangle wave T_R 's cycle is exactly equal to the cycle of the master VCO T_M).

If it's the other way round, and the slave is at a higher frequency than the master ($f_M < f_S$) then it still follows the master's frequency (Fig. 13 b: the slave's cycle T_R matches the master VCO's cycle), but the waveform is also actually altered by the changes in direction the master imposes on it. Harmonic sidebands are created, which can produce interesting timbral changes.

The way Hard Sync is implemented on the A-111 differs from the system on the A-110 standard VCO, which imposes a change of direction on the slave only at every other edge of the master waveform. Because the A-111 master sends a change to the slave at its positive as well as negative edges, when the slave frequency is higher than the master ($f_M < f_S$) the process produces richer side bands, and more interesting timbres.

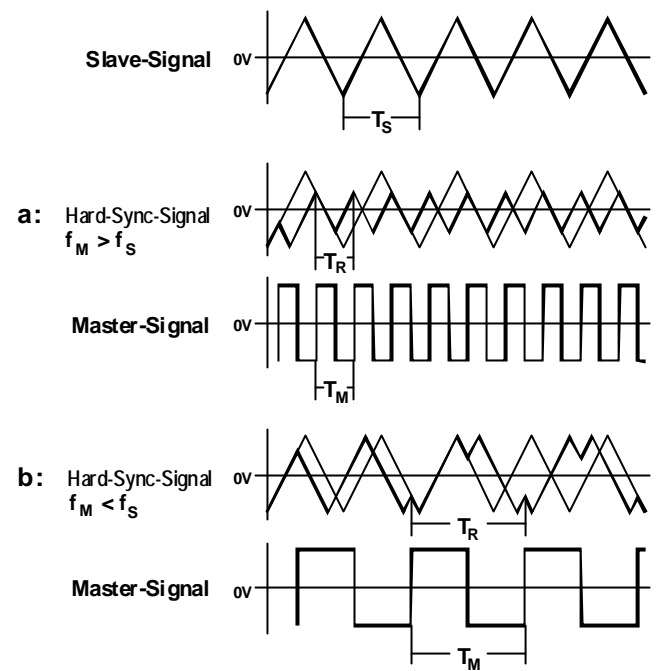

Fig. 13: Hard sync on the A-111

Soft Sync

In contrast with hard sync, soft sync produces **no change in the waveform** of the slave VCO. The master VCO simply forces the slave's waveform direction changes to match its own.

That simply means that the **slave VCO's frequency f_s** is increased, to become an **exact multiple of the master VCO's**.

In fig. 14 you can see that the frequency of the 'synced' triangle wave f_r is forced into being exactly double that of the master VCO f_m (or, to put it another way: cycle T_M is twice the length of cycle T_R).

Soft Sync, because there is no change in the slave's actual waveform shape, can't produce timbral variations. What it does instead is to lock **two or preferably more oscillators into a perfect harmonic relation**, to produce a particular sort of timbre.

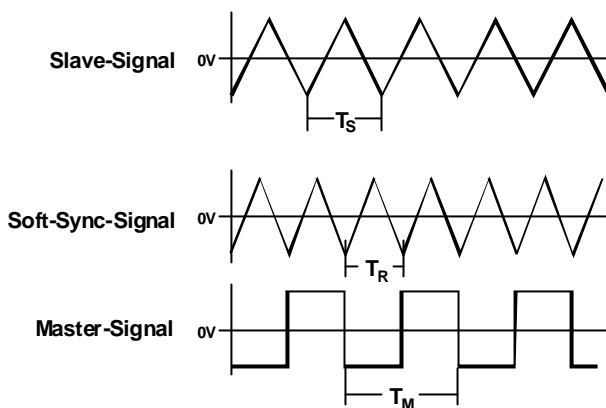

Fig. 14: Soft sync on the A-111

4. Controls

1 Range

Footage (the octave of the fundamental) is controlled with this knob. Seven settings are available, covering a very wide frequency range.

2 Tune • 3 Fine

Use these two controls to tune the VCO. The Tune control 2 is for **coarse tuning**, and can alter the VCO's frequency roughly $\pm \frac{1}{2}$ octave. The Fine control 3 is for **fine tuning**.

For total accuracy, an electronic tuner is recommended.

P If two or more oscillators are controlled by the same control voltages, and set to the same footage, you can use the Fine knob to de-tune one or more of the oscillators relative to each other. This can produce vibrato and chorus-like effects, perfect for soundscapes and generally rich timbres.

4 CV 2

The **pitch of the VCO** is controlled by the voltages present at inputs ! and ". The level of CV input " can be controlled with the **Attenuator 4** .

5 PW

Use control 5 to adjust the **pulse width** of the rectangle wave which is output at socket = (see fig. 2 in chapter 3.1).

6 PCV

The pulse width of the rectangle wave can also be altered or modulated by voltage control (see chapter 6, User examples). Patch a CV in at input & and adjust its level with the **attenuator 6**.

7 Lin. FM

Use **attenuator 7** to adjust the **amplitude** of the **linear FM signal** patched into socket S.

5. In- / Outputs

! CV 1 • " CV 2

Sockets ! and " are the **voltage control inputs** for controlling **VCO pitch**. The voltages at these inputs are summed. Input ! is set to exactly 1 V/octave, and is normally used for pitch control - for instance from a MIDI-CV interface, controller keyboard with 1V/octave output, or the CV output from an MAQ 16/3 sequencer.

Additionally there is an internal CV input with 1V/octave connected to CV of the **system bus**. This signal (for instance the CV from a keyboard via a Bus Access module A-185), additionally controls the pitch of the VCO.

H If you are planning not to use the system bus CV - ie. if there's no CV signal being sent to the bus - you should disconnect the bus from the module, by removing jumper **J1** (at the top right of the main circuit board on the A-111, underneath the ribbon cable - see chapter 7, Appendix). If you don't, there's the possibility of interference, caused by the system bus CV line acting as an aerial. If you should later want to use the system bus CV, then simply re-install the jumper.

Input " is used for **exponential FM** in the sub-audio as well as the audio range; the level of its signal sent to the VCO is controlled by attenuator 4.

§ Lin. FM

Socket § is the Linear FM input. Level is controlled by attenuator 7.

H This input is only suitable for modulation in the audio range (> 50 Hz), because with lower frequencies there is the possibility of pitch instability.

\$ H-Sync • % S-Sync

Sockets \$ and % are the synchronisation inputs. Socket \$ is for **hard sync**, and socket % for **soft sync**.

& PCV

Socket & is the **pulse width** voltage control input socket for the VCO's rectangle wave. The level of voltage can be adjusted with attenuator 6. Fig. 15 shows pulse width modulation with an LFO.

/ □ • ((^ • = ~

Sockets / to = are the VCO **outputs**, each sending out a different waveform: **rectangle wave** (/), **sawtooth** ((), **triangle** (^) and **sine wave** (=).

The frequency of the waveforms at outputs / to = is always the same for all.

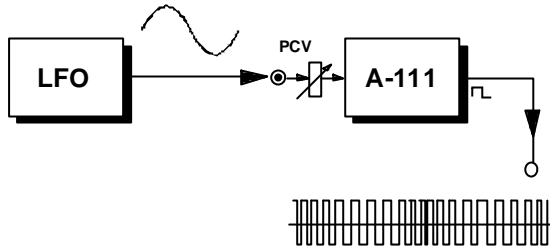

Fig. 15: Modulation of pulse width by an LFO

6. Patch-Sheet

The following diagrams of the module can help you recall your own **Patches**. They're designed so that a complete 19" rack of modules will fit onto an A4 sheet of paper.

Photocopy this page, and cut out the pictures of this and your other modules. You can then stick them onto another piece of paper, and create a diagram of your own system.

Make multiple copies of your composite diagram, to use for remembering good patches and set-ups.

- P
- Draw in patchleads with coloured pens
 - Draw or write control settings in the little white circles

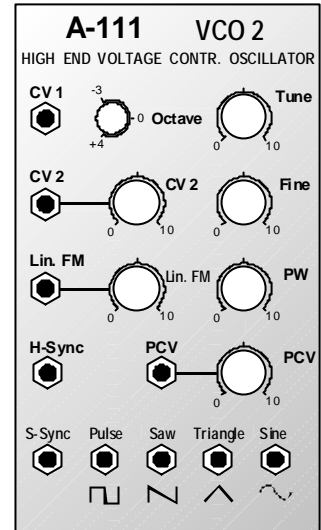
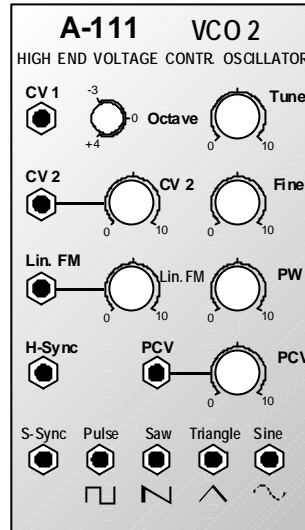

7. Appendix

The diagram on the right shows the layout of the A-111 main circuit board.

If you want to disconnect the normalised CV 1 socket from the system bus INT. CV line (see also page 12), remove **Jumper J1** from the circuit board. It is just under the ribbon cable at the top right of the board. It will be easier to disconnect the cable before removing the jumper. Don't forget to re-connect the cable afterwards.

If at a later date you want to use the internal CV connection again, then simply reverse this procedure, to put the jumper back on.

